

# QTM7

## FLOW RESTRICTOR VALVE

### SERIES 10

**MODULAR VERSION**  
**ISO 4401-07 (CETOP 07)**

**p** max **350** bar  
**Q** max **250** l/min

#### MOUNTING INTERFACE

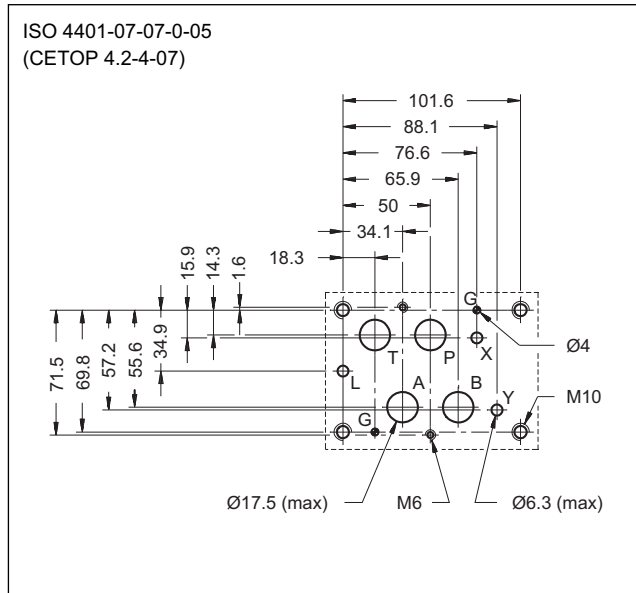

#### OPERATING PRINCIPLE

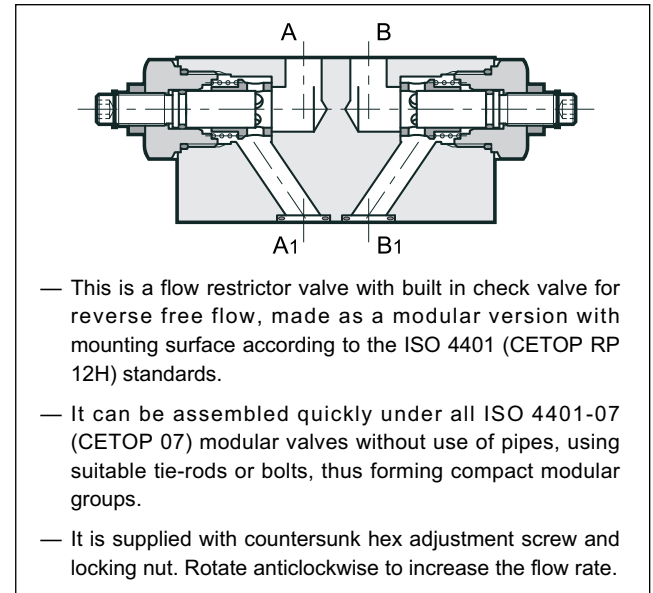

#### CONFIGURATIONS (see hydraulic symbols table)

- Configuration "SA": Allows the flow control exiting from the actuator on line A.
- Configuration "D": Allows independent control of the flow exiting from the chambers A and B of the actuator.
- All the configurations have a built-in check valve that allows free reverse flow (cracking pressure of 0,7 bar).

#### PERFORMANCES (measured with mineral oil of viscosity 36cSt at 50°C)

Maximum operating pressure	bar	350
Maximum flow rate	l/min	250
Leakage flow with restrictor closed	l/min	≤ 0,5
Check valve opening pressure	bar	0,7
Ambient temperature range	°C	-20 / +50
Fluid temperature range	°C	-20 / +80
Fluid viscosity range	cSt	10 ÷ 400
Fluid contamination degree	According to ISO 4406:1999 class 20/18/15	
Recommended viscosity	cSt	25
Mass: QTM7-SA	kg	7,35
QTM7-D	kg	7,7

#### HYDRAULIC SYMBOLS

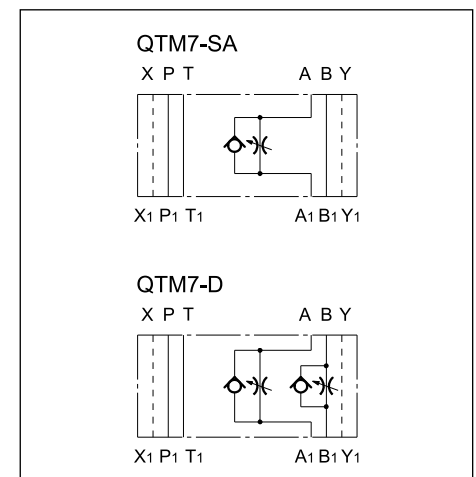

**1 - IDENTIFICATION CODE**

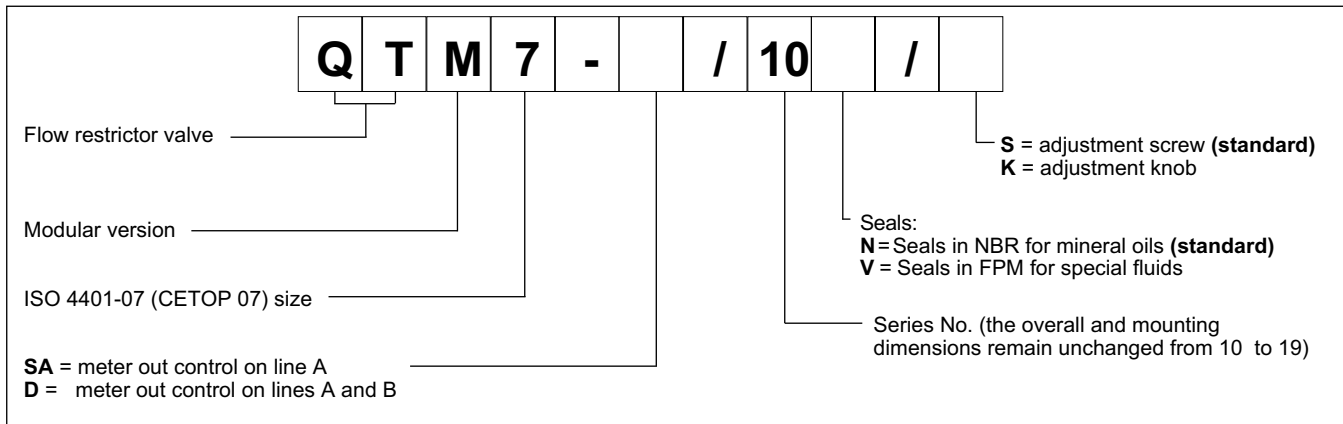

**2 - CHARACTERISTIC CURVES** (values obtained with viscosity of 36 cSt at 50°C)

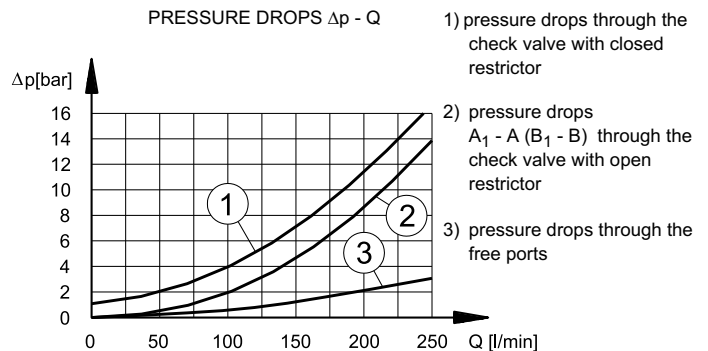
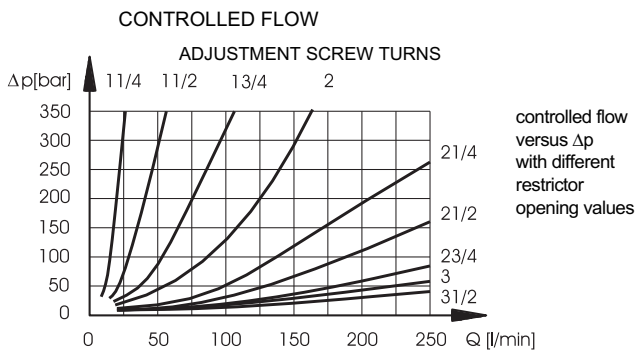

**3 - HYDRAULIC FLUIDS**

Use mineral oil-based hydraulic fluids HL or HM type, according to ISO 6743-4. For these fluids, use NBR seals. For fluids HFDR type (phosphate esters) use FPM seals (code V). For the use of other kinds of fluid such as HFA, HFB, HFC, please consult our technical department. Using fluids at temperatures higher than 80 °C causes a faster degradation of the fluid and of the seals characteristics. The fluid must be preserved in its physical and chemical characteristics.

**4 - OVERALL AND MOUNTING DIMENSIONS**

