



Tipo / Type

FPUN-*.*.*.*

Sez./Section

I

Pag./Page

051/1

Valvola regolatrice di flusso unidirezionale
Restrictor valve

Rev.00-2016/08

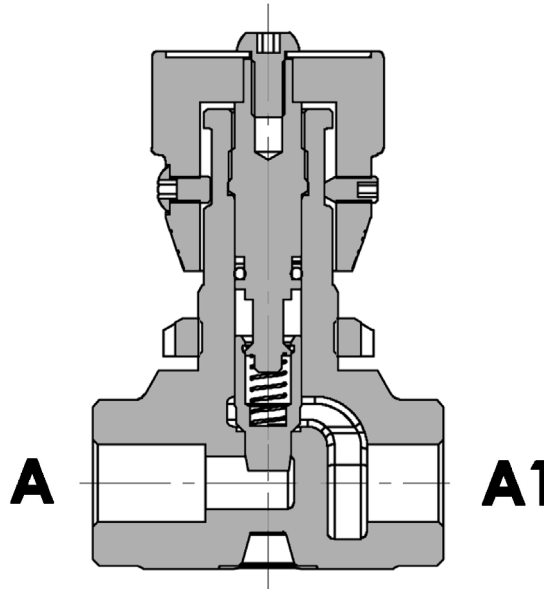
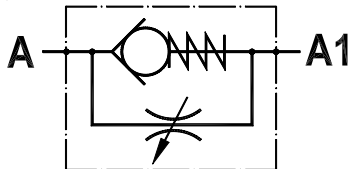

SPECIFICHE TECNICHE

Materiali: corpo e parti interne in acciaio. La superficie esterna è protetta mediante zincatura.

Portata max.: fino a 90 l/min

Pressione max.: 400 bar, vedasi tabella pag.02

Pressione di apertura: standard 0,5 bar

TECHNICAL SPECIFICATIONS

Materials: body and internal parts are steel made. External surface zinc plated.

Rated flow: up to 90 l/min

Max. pressure: 400 bar, see data sheet page 02

Cracking pressure: 0.5 bar standard

DIAGRAMMA PERDITE DI CARICO - PRESSURE DROP CURVES

Viscosità olio 24 mm²/sec. (3,5 °E)
Temperatura 50 °C

Oil viscosity 24 mm²/sec. (3,5 °E)
Temperature 50 °C

A → A1
VALVOLA CHIUSA

A → A1
VALVOLA APERTA

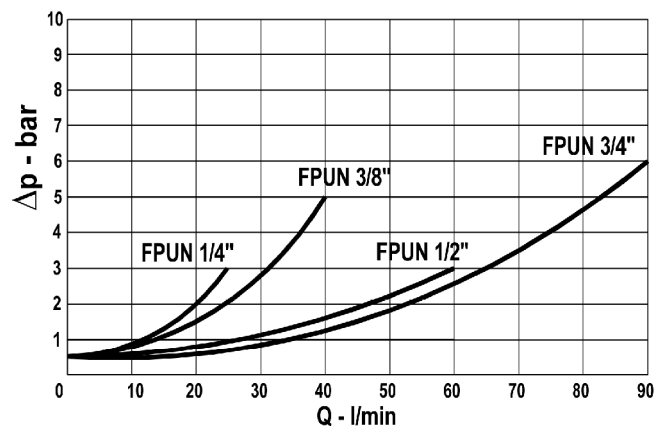
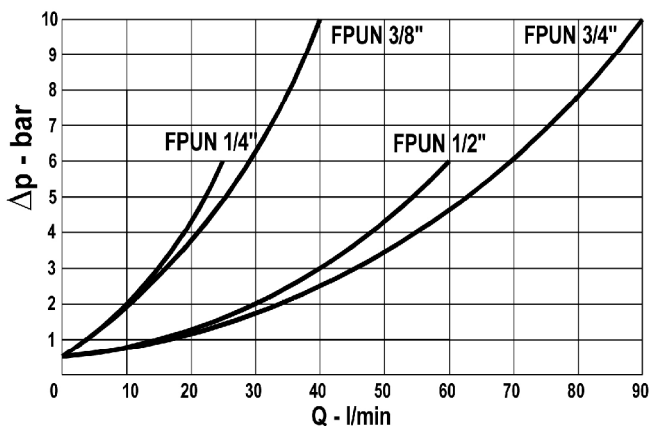



Valvola regolatrice di flusso unidirezionale
Restrictor valve

Rev.00-2016/08

VITE DI FERMO: COPPIA MASSIMA
DI SERRAGGIO - 0,8 N/m

LOCKING SCREW: MAX. INSTALLATION
TORQUE - 0,8 N/m

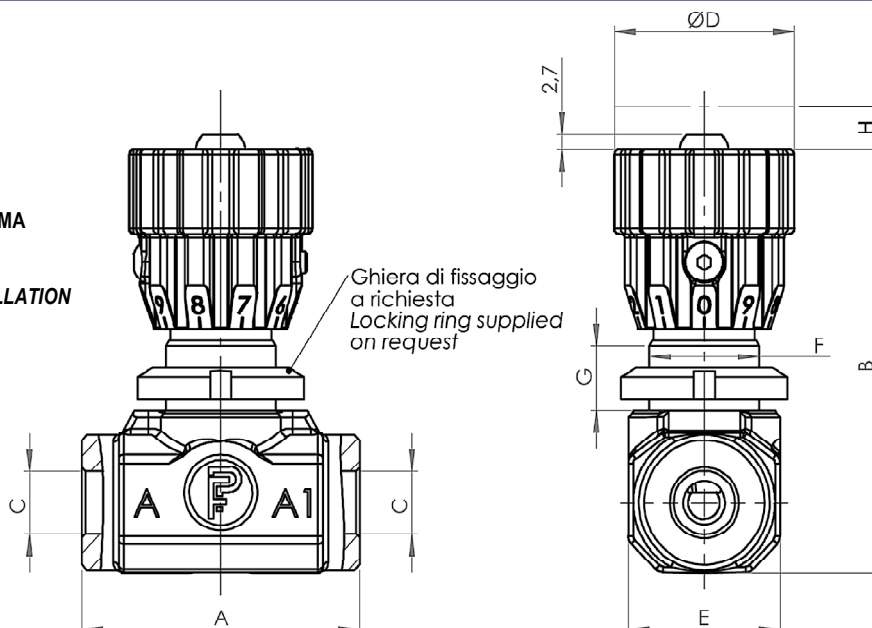

TIPO TYPE	PORTATA MAX. MAX FLOW	PRESSIONE MAX. MAX PRESSURE	A	B	C	D	E	F	G	H	PESO WEIGHT
	L/MIN	BAR	mm	mm	BSPP	mm	mm	mm	mm	mm	Kg
FPUN 1/4"	25	400	53	78	1/4"	35	29	M21X1	13	7.5	0.340
FPUN 3/8"	40	400	53	78	3/8"	35	29	M25X1.5	13	7.5	0.360
FPUN 1/2"	60	400	68	95	1/2"	40	40	M30X1.5	14	8.5	0.810
FPUN 3/4"	90	350	68	95	3/4"	40	40	M35X1.5	14	8.5	0.780

ISTRUZIONI PER IL MONTAGGIO A PANNELLO
INSTRUCTIONS FOR PANEL MOUNTING

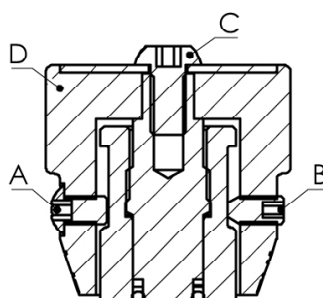

Togliere le viti "A" di fine corsa, "B" di bloccaggio regolazione e "C" di fissaggio pomolo; sfilare il pomolo "D" ed installare la valvola a pannello fissandola con relativa ghiera.
Rimontare nell'ordine inverso i particolari precedentemente smontati.

Remove the screw "A" of limit stop, "B" for blocking and regulation, "C" of handwheel fixing; withdraw the handwheel "D" and install the panel-valve by fixing it with the relative metal ring.
Re-assemble in reversed order the parts previously disassembled.

ESEMPIO DI ORDINAZIONE - ORDERING CODE EXAMPLE

FPUN 1 / 2 0 , 5 F *

1/4 . 1/4" BSPP
3/8 . 3/8" BSPP
* 1/2 . 1/2" BSPP
3/4 . 3/4" BSPP
Connessioni - Port sizes

0.5 bar (std)
* Pressione apertura ritegno
Cracking pressure

Guarnizioni . Seals:
V=Viton *
Omettere se BUNA-N . Omit if BUNA-N

F . ghiera di fissaggio . locking ring *
Omettere se non richiesta . omit if not requested