

Valvola overcenter doppia, montaggio a flangia
Dual overcenter valve, gasket mounted

Rev.02-2010/05

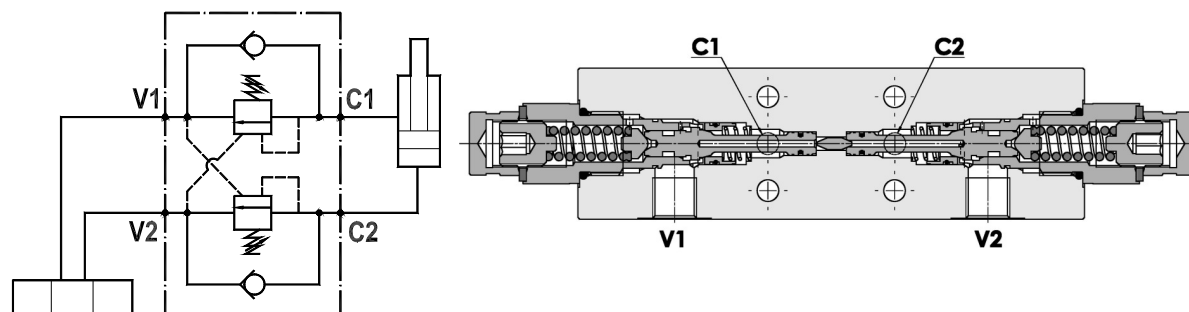

SPECIFICHE TECNICHE

Materiali: corpo in acciaio zincato. I componenti interni sono in acciaio trattato termicamente.

Portata max.: 35 l/min

Taratura max.: 350 bar

Rapporto di pilotaggio: 1 : 4 (a richiesta 1 : 8, 1 : 11)

Regolazione pressione: mediante vite

Campo di regolazione pressione: vedere pag.02

Peso: 2,000 Kg

TECHNICAL SPECIFICATIONS

Materials: body is in steel zinc plated. Internal parts are in hardened steel.

Rated flow: up to 35 l/min

Max. setting: 350 bar

Pilot ratio: 1 : 4 (1 : 8 and 1 : 11 on request)

Adjustment means: leakproof screw.

Adjustable pressure range: see page 02

Weight: 2,000 Kg

DIAGRAMMA PERDITE DI CARICO - PRESSURE DROP CURVES

Viscosità olio 24 mm²/sec. (3,5 °E)
 Temperatura 50 °C

Oil viscosity 24 mm²/sec. (3,5 °E)
 Temperature 50 °C

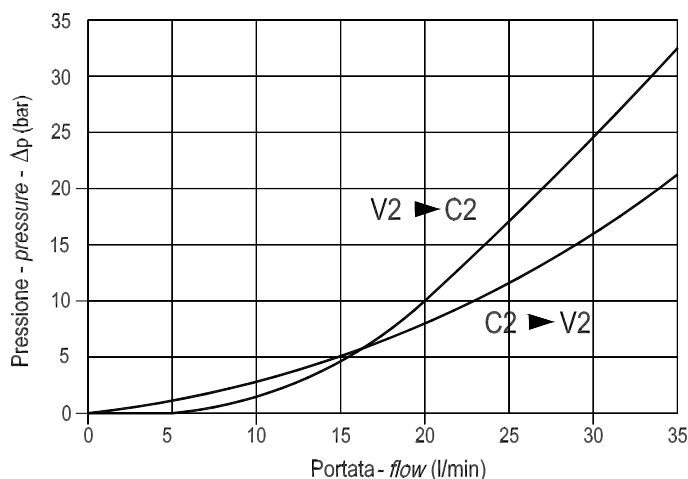

Valvola overcenter doppia, montaggio a flangia
Dual overcenter valve, gasket mounted

Rev.02-2010/05

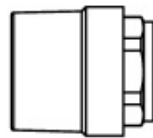
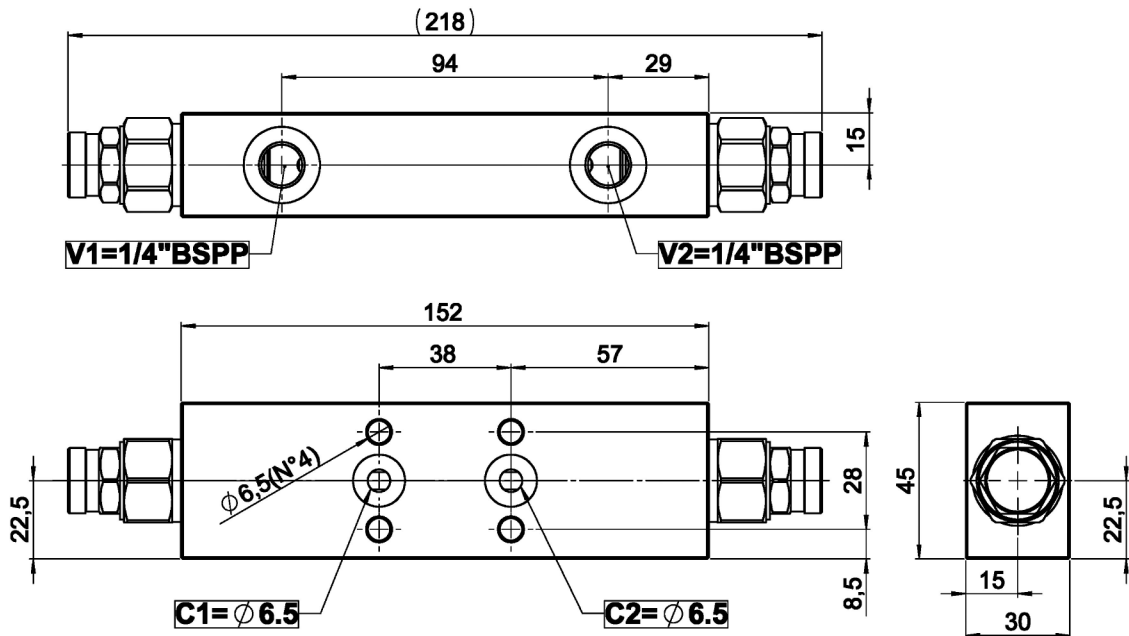

Cappello antimanomissione.
Codice di ordinazione: 9006800030

Tamperproof cap.
Ordering code: 9006800030

MOLLE - SPRINGS				*
Codice Code	Rapp. pil. Pilot ratio	Campo taratura min.-max. bar Adjustable pressure range bar	Increment. press. bar/giro vite Pressure increase bar/turn	Taratura standard bar Standard setting bar
20	1 : 4	60 - 250	65	170
	1 : 8	100 - 350	110	
35	1 : 8	80 - 350	140	280
	1 : 11	80 - 350	160	

ESEMPIO DI ORDINAZIONE - ORDERING CODE EXAMPLE

F P O **3 5** **D** **1 / 4** **2 F** **3 5** **B**

* "20" / "35":
 Campi di taratura pressione - *Adjustable pressure range*

Rapporto di pilotaggio - *Pilot ratio*
 Omettere se std - *Omit if std* *
 B = 1 : 8, C = 1 : 11