

**MATERIALS**

BODY	11 S MN P8 30 - UNI EN 10087
NEEDLE	1 C 40 - UNI 8373
OR	MESCOLA NITRICA
ANTIEXTRUSION RINGS	PTFE
KNOB	GD AL SI 12 - UNI EN AB 46100
KNOB (MP)	ABS

**EXAMPLE FOR ORDERING**

	CODE	TYPE	VITON SEAL	KNOB IN PLASTIC
STEEL	FT 266/2	34	V	MP
STAINLESS STEEL	FT 2266/2	34	-	MP

**SEAL KIT ON THE SEATING**

TYPE	1 (OR)	2 (BK)	(3)
34	2037	266/6.022.00.1-34	2068
78	2050	267/2.022.00.1-38	3075

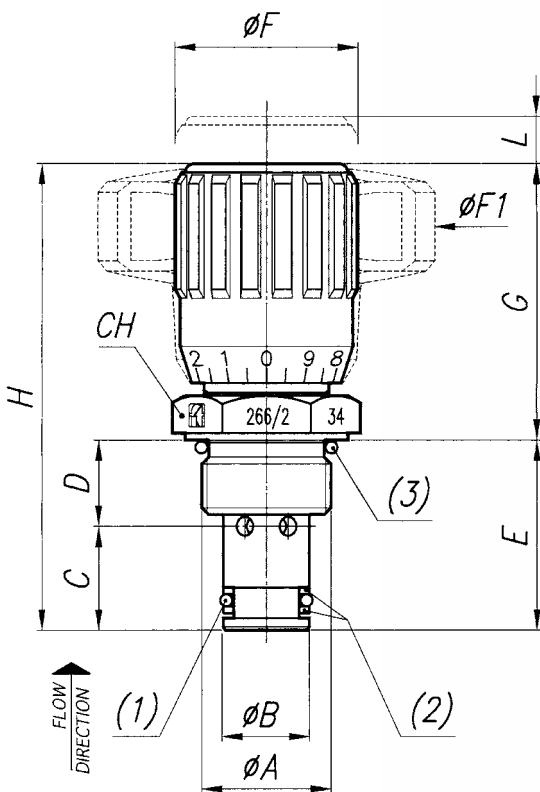
**DIMENSIONS**

TYPE	ØA UNI 4534	ØB	C	D	E	ØF	ØF1	G	H	L	CH	WEIGHT KG
34	3/4"-16 UNF	12,7	15,3	12,7	28	27	50	40,7	68,7	6	24	0,112
78	7/8"-14 UNF	15,8	17,5	15	32,5	33	70	46	78,5	8	27	0,115

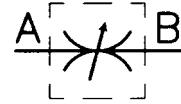

## CARTRIDGE MOUNTED DOUBLE-ACTING CONTROL VALVES MAX 350 BAR

They control a free flow in both directions.

### On request

- Complete with Viton seals (V)
- Knob in ABS (mp)
- Version in AISI 316 code FT 2266/2



FT 266/2-UNF

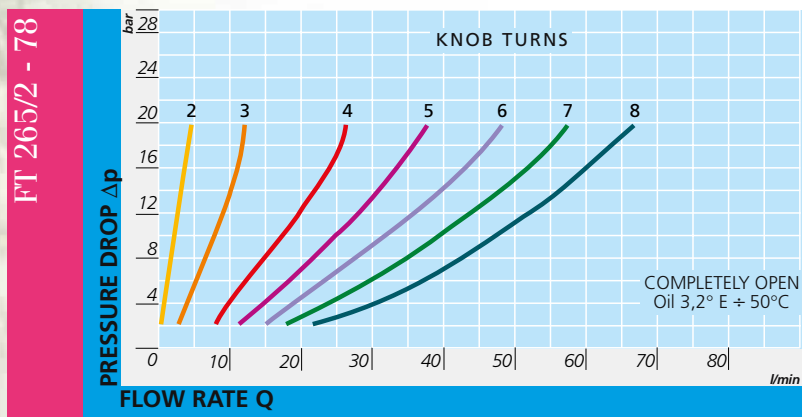
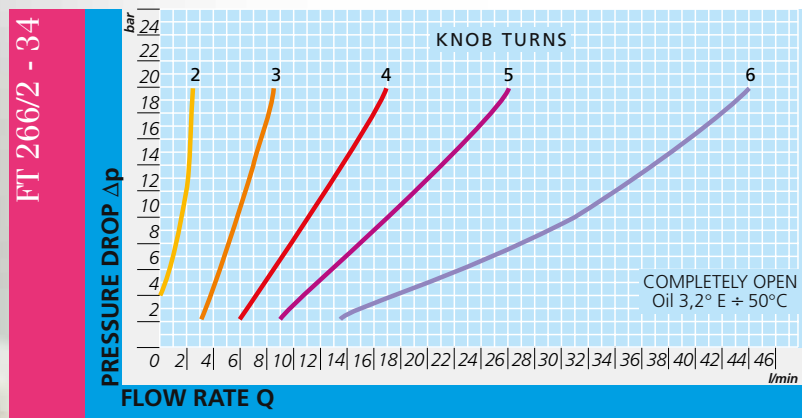

## TECHNICAL DATA

TYPE	FLOW SECTION CM <sup>2</sup>	MAX. WORKING PRESSURE BAR	MIN. BURSTING PRESSURE BAR	WORKING TEMPERATURE °C	FILTRATION GRADE $\mu$ M ABSOLUTE
34	0,20	320	1300	-20°/+100°	25
78	0,50	320	1300	-20°/+100°	25



Sealing realized  
with OR seals  
on conical seating  
for UNF threads

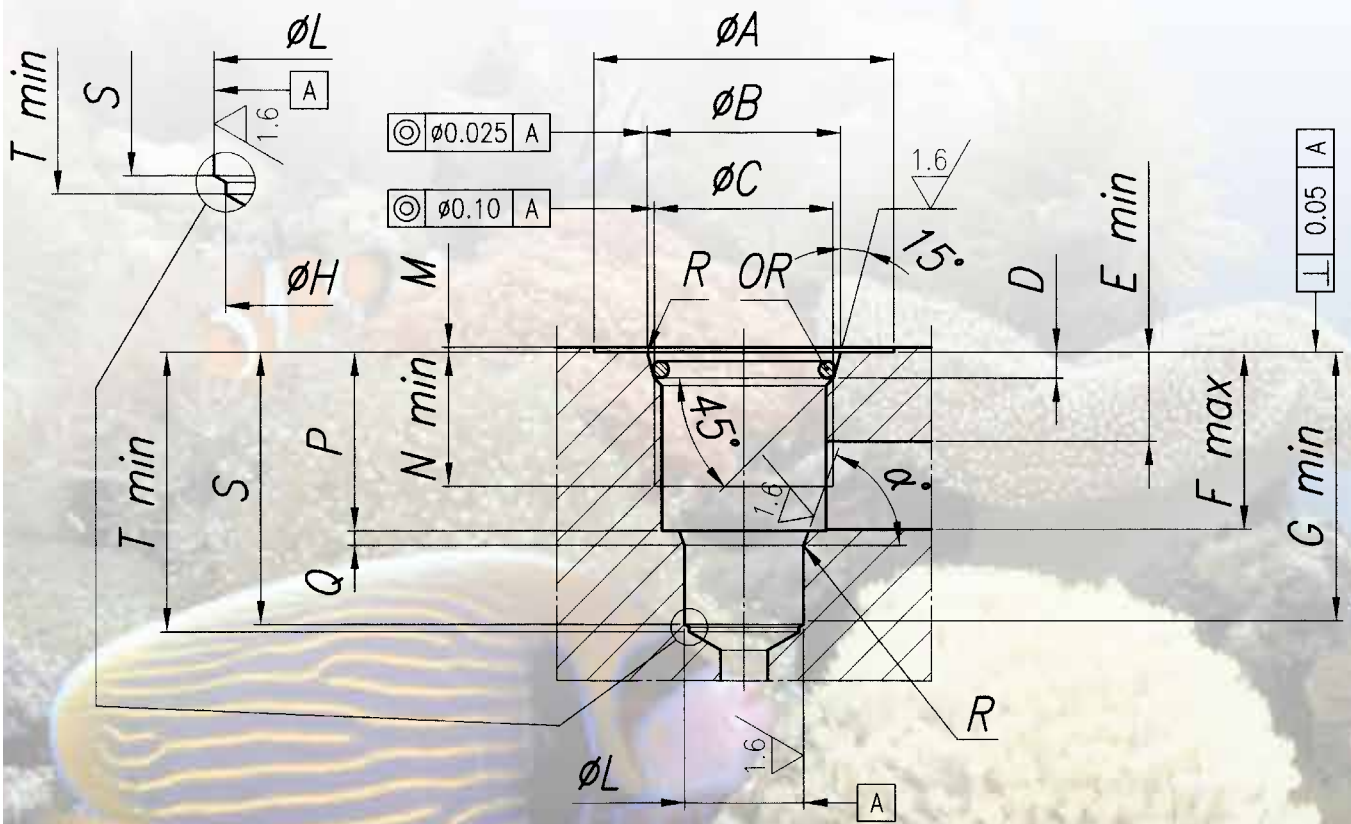

# DRAWING OF CAVITY MACHINE FOR CARTRIDGE MOUNTED VALVES



FT 265/2 - 266/2 - 266/5 - 266/6 - 268/2

## CONICAL SEATING FOR OR FT 265/2 - FT 266/2 FT 266/5 - FT266/6 - 268/2

TYPE	ØA	ØB	<sup>C</sup> UNI 4534	D	E	F	G	ØH	ØL
34	32 $\pm$ 0,4	20,65 $\pm$ 0,1	3/4"-16UNF-2B	2,75	9,5	18,9	28,6	11,7	12,7 $^{+0,05}_{-0}$
78	32 $\pm$ 0,4	24 $\pm$ 0,1	7/8"-14UNF-2B	2,75	12,35	24,25	31,85	15	15,875 $^{+0,05}_{-0}$

## CONICAL SEATING FOR OR FT 265/2 - FT 266/2 FT 266/5 - FT266/6 - 268/2

TYPE	M	N	P	Q	R	S	T	α°	OR
34	0,5	14,3	19,05 $\pm$ 0,13	1,53 $\pm$ 0,08	0,1 $^{+0,15}_{-0}$	29 $\pm$ 0,4	29,8	70°	2068
78	0,5	15,75	24,45 $\pm$ 0,1	1,4 $\pm$ 0,1	0,1 $^{+0,15}_{-0}$	33,75 $\pm$ 0,4	34,5	60°	3075